

voran[®]

machinery

Packing presses 100/180P2



Liquid gold

Ergonomics meets efficiency

Our packing presses enable a more efficient pressing process. The pivot operation enables the emptying and filling of the second container during the pressing process. Depending on the desired production quantity, we deliver packing presses in two different sizes: with hourly output of 600 (100P2) or 1,200 kilograms (180P2). The result is always clear: up to 75% yield with a very low suspension ratio.

The highlights of the 180P2

- All parts that come into contact with the fruit are made of food-grade stainless steel, wood or plastic.
- Simple operation
- Hydraulic cylinders located below—hydraulic oil cannot enter the mash
- Presses with flat position without foundations
- Massive design
- Over-pressure valve
- A press ram subdivided by inserts ensures the juice runs off quickly. This has a high work speed therefore lower oxidation.

Get the most out of your fruit.

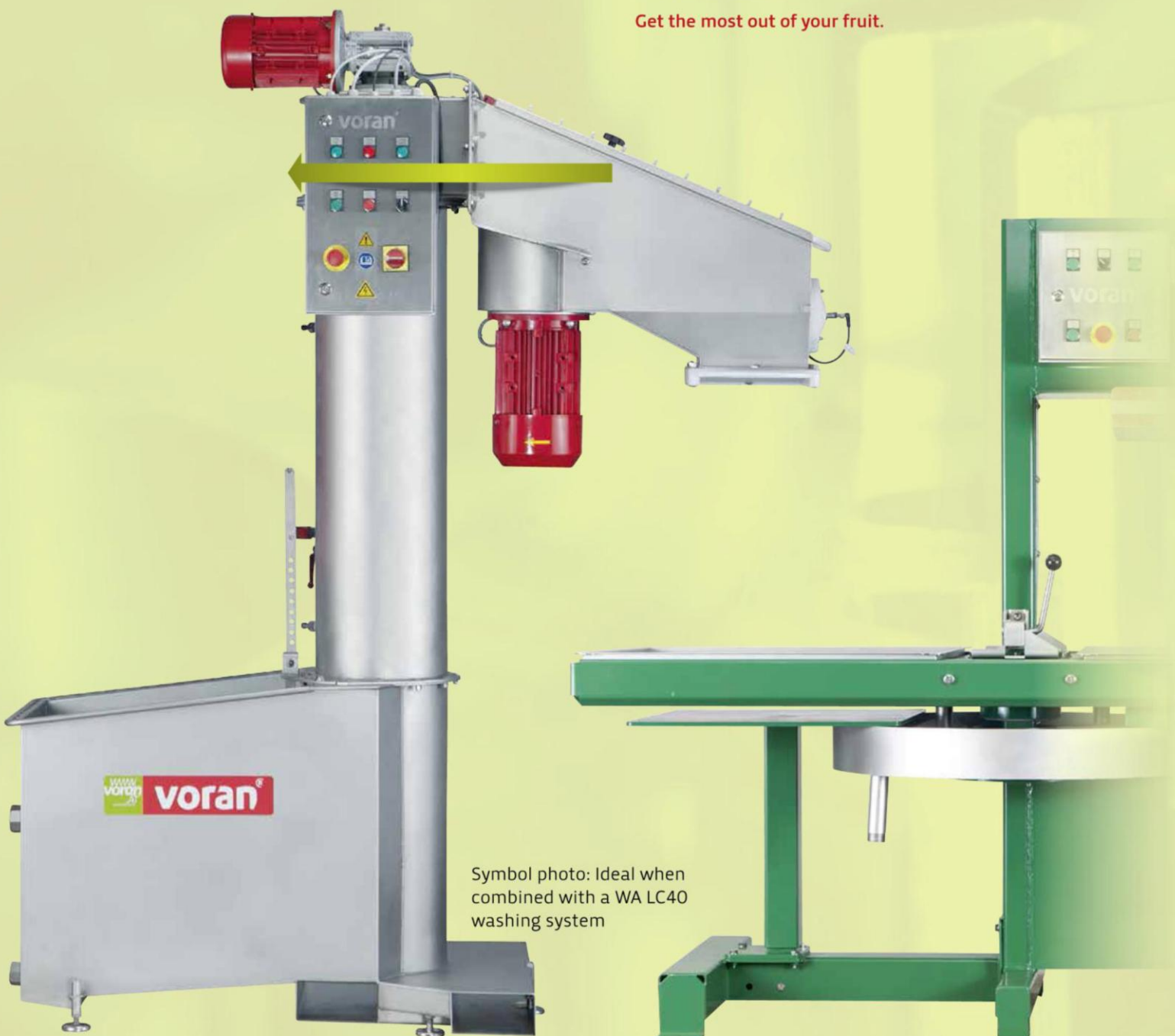

Symbol photo: Ideal when combined with a WA LC40 washing system

The Topseller — 100P2

Everything you need

We can tell you why the 100P2 is so popular with our customers: it is a straightforward investment that pays for itself quickly even with a low number of fruit trees. The excellent production quality and accompanying long lifespan of the machine are additional arguments.

If you can deal with an hourly output of around 600 kilograms, the voran® 100P2 packing press is the right choice. If you need higher performance, you will find the right machine on the following pages.

100P2—compact, high-quality, affordable.

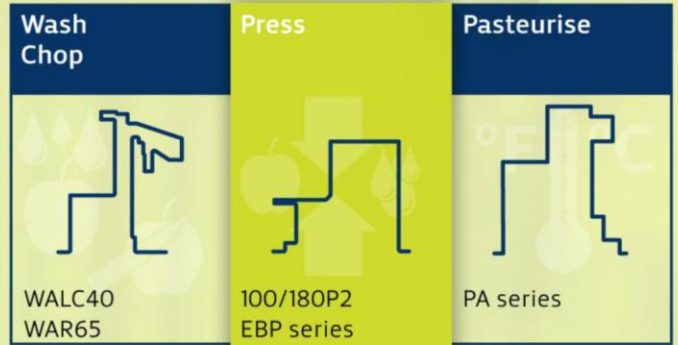

Efficient drive unit with 1.5 kW output

Massive press unit for maximum juice yield

Robust, torsionally stiff steel profile frame, powder-coated

Filling tray can be loaded during the pressing process

Central juice drain

Technically mature hydraulic device with 25 tonne pressing force

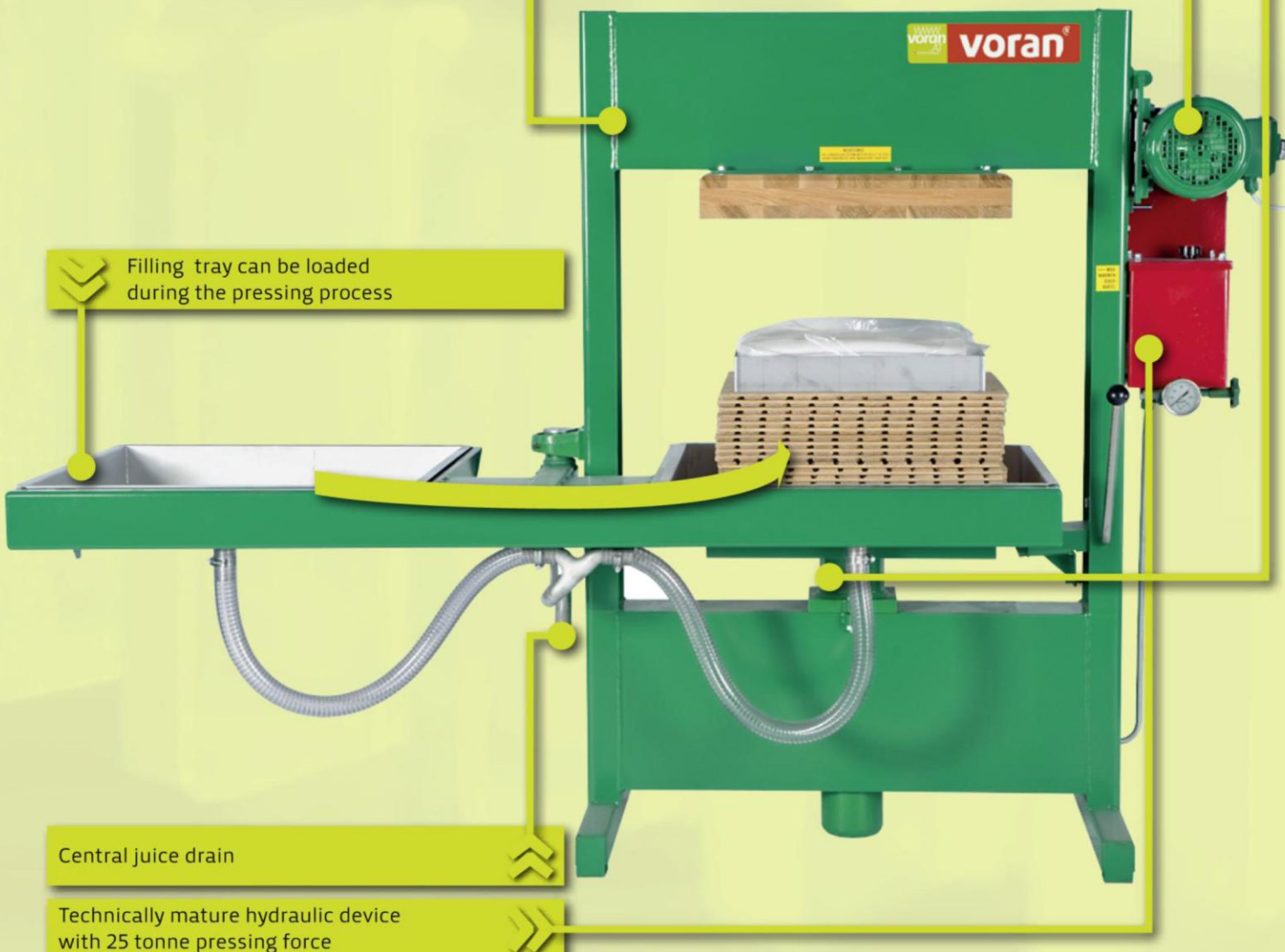

The work horse — 180P2



Packing press 180P2 without lift/lower device



Packing press 180P2 with lift/lower device

Accessory package

Acacia wood or stainless steel press inserts and fabrics made from resistant polyester

Packing press 180P2 with lift/lower device

Simple machine cleaning due to internal piping and cabling

Electro-mechanical piston lift limitation

Automatic maintenance of pressing force

Removable juice collection containers for simple cleaning

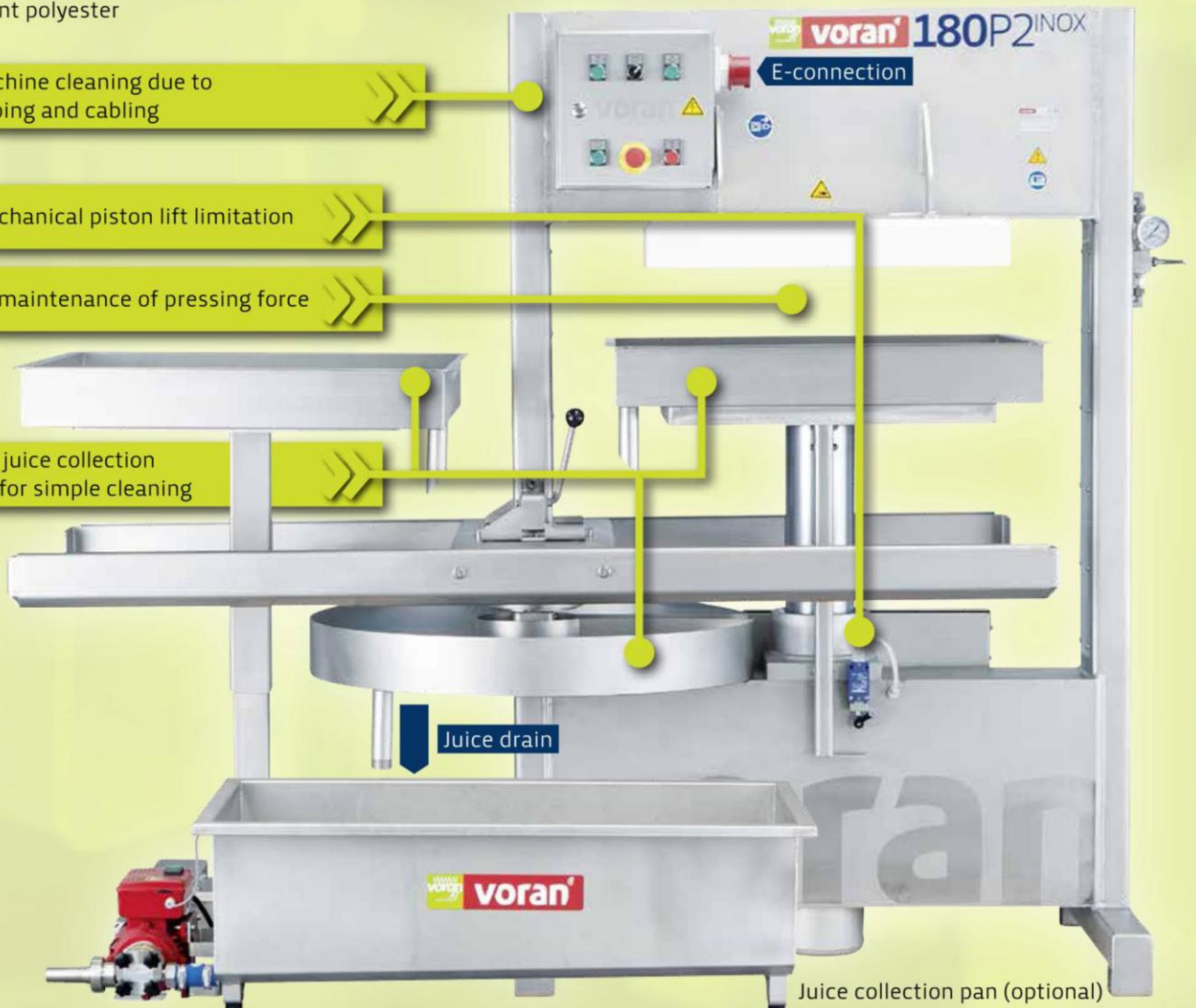

Juice collection pan (optional)

Technical data

100P2

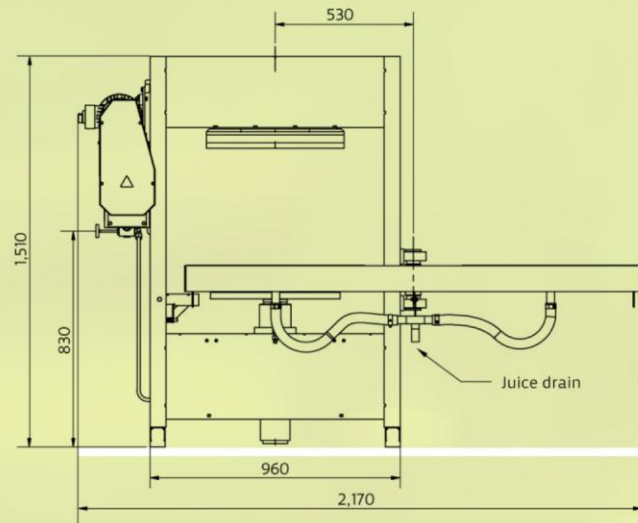

180P2

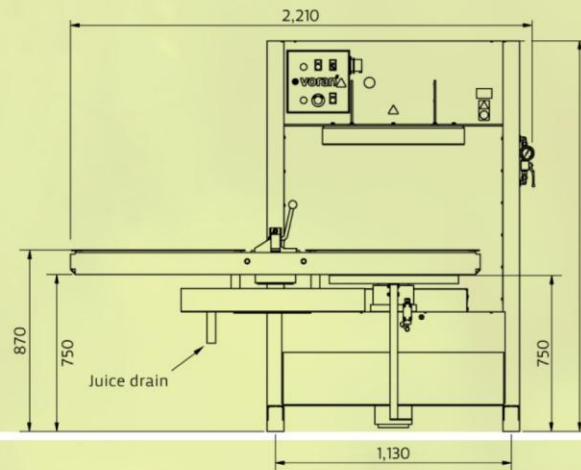

180P2 with lift/lower device

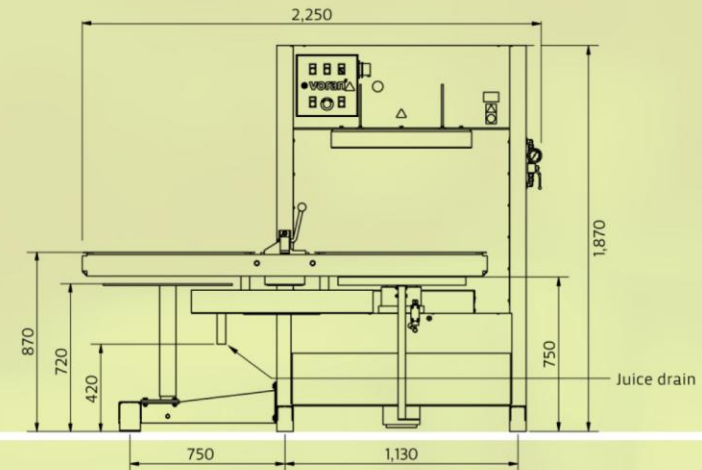

Type	100P2	180P2 / 180P2 inox
Maximum hourly output in l/h	600	1,200
Power consumption in kW	1.5	2.2
Electrical connection*	400V / 50Hz (three-phase)	400V / 50Hz (three-phase)
Dimensions length/width/height in mm	2,170 / 730 / 1,510	2,250 / 850 / 1,870
Weight in kg	295	1,020
Insert size in cm	50x50	65x65
Fabric size in cm	80x80	100x100
Design	Steel coated	Steel coated/stainless steel
Delivery scope	18 press fabrics 80x80 cm, 20 press inserts 50x50 cm**	24 press fabrics 100x100 cm, 26 press inserts 65x65 cm**

*Other voltages and net specifications on request

**complies with EC 1935/2004 **for 180P2 inox made of stainless steel, otherwise acacia wood



voran.at

voran business lines

machines

machine construction

plant construction

facades

How to find us



voran Maschinen GmbH
Sales
Linzer Strasse 30
A 4650 Edt bei Lambach
T +43(0)72 49 / 444-0
F +43(0)72 49 / 444-888
office@voran.at
www.voran.at

Production
Inn 7
A 4632 Pichl bei Wels

Service hotline
T +43(0)72 49 / 444-200